

MYSON POWER EXTRA

SPRING RETURN ZONE VALVE

MPE 222 / MPE 2 3/4 “- 2 PORT 22mm VALVE

Thank you for choosing a MYSON heating control.

The MPE 222 is designed to control water circulation in primary hot water or central heating circuits. The motor is powered to open the valve with a spring return to the closed position.

The valve is not directionally sensitive and may be fitted with flow through either Port A or Port B.

For convenience the neon indicator light illuminates, indicating when the valve is open.

When the manual lever is moved to the right, the valve is open. This is used when filling, venting or draining the system. The spring return valve rests in the closed position.

TECHNICAL SPECIFICATION

Motor Supply Voltage	230 V AC
Frequency	50 Hz
Power Consumption	6 W
Motor Insulation Rating	Class ‘F’
Maximum Working Pressure	10 Bar
Maximum Water Temperature	95° C
Maximum Ambient Temperature	52° C
KV value	6.7
Switch Rating	3(0.5) A
High Temperature Silicon Cable	1100mm
Valve Body	Brass with spring loaded Mica filled PTFE shoes
Actuator	Power to Open Spring to Close

INSTALLATION INSTRUCTIONS

Step 1. Select Valve Position:

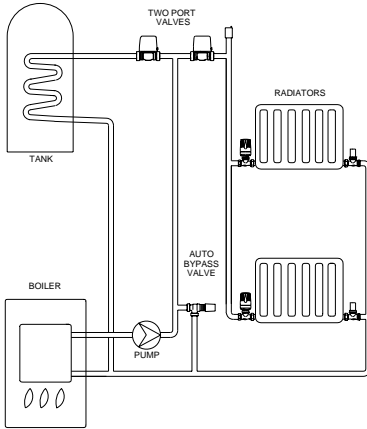

Choose a suitable position for the valve in the circuit to be controlled, which allows sufficient access for wiring and maintenance.

The position chosen must not isolate the boiler from the open vent or the cold feed pipe work.

The valve may be fitted in a horizontal, vertical or inclined orientation and may be fitted on either the flow or return circuit.

The actuator **must not** be fitted below the valve body.

Step 2. Fit Valve Body to Pipe work:

Fit the valve body using the 22mm compression nuts provided. Ensure that the valve body is only gripped on the hexagonal faces at the valve ports. Take care not to over tighten.

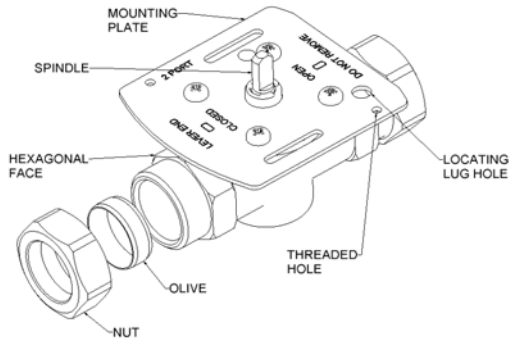

Step 3. Fit Actuator to Valve Body:

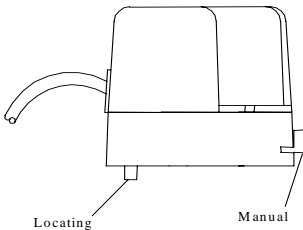

Position the actuator on the valve body by locating the spindle in the cam slot.

Rotate actuator until the locating lug (shown) lines up with locating lug-hole on the mounting plate (shown).

Fix the actuator to the body by *lightly* tightening the screws provided.

Set the override lever to MAN. Fill, test and thoroughly flush the system.

Step 4. Electrical Connections:

The actuator is fitted with 1100mm of 4-core cable for connection of the system equipment. The installation will be simplified by the use of an electrical junction box into which all the system equipment can connect.

The actual wiring connections will depend on the system equipment used, following the wiring principle outlined below. The MPE 222 is double insulated and requires no earth connection.

IMPORTANT:

The wiring must comply with current I.E.E. regulations. Ensure mains supply to all controls is fused at no more than 3A. Mains isolating switch must have contact separation of at least 3mm.

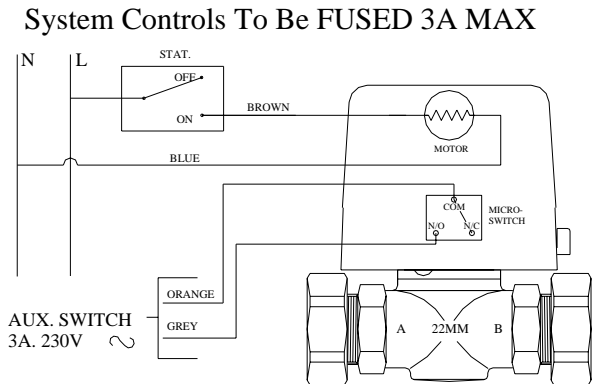

Step 5. Commissioning:

When the installation is complete, filled and vented, check that the valve operates correctly. Switch on the system controls, i.e. programmer and thermostats: The valve should move to the open position. When fully open any equipment connected to the valve's auxiliary switch should operate.

Switch off the heating controls: The valve should spring return to the closed position and auxiliary equipment should cease to operate.

Notes:

- Ensure that the actuator is not covered with thermal insulation, or in contact with pipe work or other materials.
- When the valve is fitted in confined space, ample ventilation must be provided to ensure that the valve is kept within the specified ambient temperature range.
- The valve actuator is not designed for continuously powered operation.

MPE 222 Spares

Description

Part No.

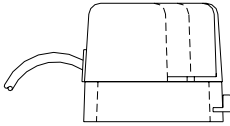

Actuator with
Fixing screws

421101

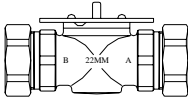

22mm 2 Port
Valve body.

421102

PRODUCT INTERCHANGE WIRING GUIDE

2-PORT ZONE 22mm

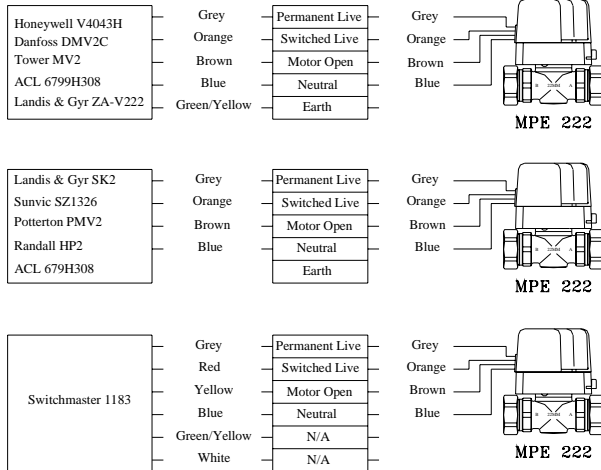

MYSON CONTROLS, MYSON LTD., EASTERN AVENUE, TEAM VALLEY,
 GATESHEAD, TYNE & WEAR, NE11 0PG
 SALES OFFICE No.: 0845-402-3434

IN ACCORDANCE WITH OUR POLICY OF CONTINUAL PRODUCT IMPROVEMENT, WE RESERVE THE RIGHT TO AMEND THE SPECIFICATION OF THESE PRODUCTS WITHOUT PRIOR NOTIFICATION