

Installation and service instructions

for contractors

VIESSMANN

Room temperature controller

OpenTherm room temperature controller with digital time switch
For Vitodens 100-W, 111-W and 050-W

Room temperature controller



Safety instructions



Please follow these safety instructions closely to prevent accidents and material losses.

Safety instructions explained



Danger

This symbol warns against the risk of injury.

Note

Details identified by the word "Note" contain additional information.



Please note

This symbol warns against the risk of material losses and environmental pollution.

Target group

These instructions are exclusively intended for qualified contractors.

- Work on gas installations may only be carried out by a registered gas fitter.
- Work on electrical equipment may only be carried out by a qualified electrician.
- The system must be commissioned by the system installer or a qualified person authorised by the installer.

Regulations to be observed

- National installation regulations
- Statutory regulations for the prevention of accidents
- Statutory regulations for environmental protection
- Codes of practice of the relevant trade associations
- Relevant country-specific safety regulations

Safety instructions (cont.)

Safety instructions for working on the system

Working on the system

- Where gas is used as the fuel, close the main gas shut-off valve and safeguard it against unintentional reopening.
- Isolate the system from the power supply, e.g. by removing the separate fuse or by means of a mains isolator, and check that it is no longer live.
- Safeguard the system against reconnection.
- Wear suitable personal protective equipment when carrying out any work.



Danger

Hot surfaces and fluids can lead to burns or scalding.

- Before maintenance and service work, switch OFF the appliance and let it cool down.
- Never touch hot surfaces on the boiler, burner, flue system or pipework.



Please note

Electronic assemblies can be damaged by electrostatic discharge.
Prior to commencing work, touch earthed objects such as heating or water pipes to discharge static loads.

Repair work



Please note

Repairing components that fulfil a safety function can compromise the safe operation of the system.

Replace faulty components only with genuine Viessmann spare parts.

Auxiliary components, spare and wearing parts



Please note

Spare and wearing parts that have not been tested together with the system can compromise its function. Installing non-authorised components and making non-approved modifications or conversions can compromise safety and may invalidate our warranty.

For replacements, use only original spare parts supplied or approved by Viessmann.

Safety instructions (cont.)

Safety instructions for operating the system

If you smell gas



Danger

Escaping gas can lead to explosions which may result in serious injury.

- Do not smoke. Prevent naked flames and sparks. Never switch lights or electrical appliances on or off.
- Close the gas shut-off valve.
- Open windows and doors.
- Evacuate any people from the danger zone.
- Notify your gas or electricity supply utility from outside the building.
- Have the power supply to the building shut off from a safe place (outside the building).

If you smell flue gas



Danger

Flue gas can lead to life threatening poisoning.

- Shut down the heating system.
- Ventilate the installation site.
- Close doors to living spaces to prevent flue gases from spreading.

What to do if water escapes from the appliance



Danger

If water escapes from the appliance there is a risk of electrocution.

Switch OFF the heating system at the external isolator (e.g. fuse box, domestic distribution board).



Danger

If water escapes from the appliance there is a risk of scalding. Never touch hot heating water.

Condensate



Danger

Contact with condensate can be harmful to health.

Never let condensate touch your skin or eyes and do not swallow it.

Flue systems and combustion air

Ensure that flue systems are clear and cannot be sealed, for instance due to accumulation of condensate or other external causes.

Ensure an adequate supply of combustion air.

Inform system users that subsequent modifications to the building characteristics are not permissible (e.g. cable/ pipework routing, cladding or partitions).

Safety instructions (cont.)**Danger**

Leaking or blocked flue systems, or an inadequate supply of combustion air can cause life threatening poisoning from carbon monoxide in the flue gas. Ensure the flue system is in good working order. Vents for supplying combustion air must be non-sealable.

**Danger**

The simultaneous operation of the boiler and appliances that exhausts air to the outside can result in life threatening poisoning due to a reverse flow of flue gas. Fit an interlock circuit or take suitable steps to ensure an adequate supply of combustion air.

Extractors

Operating appliances that exhaust air to the outside (extractor hoods, extractors, air conditioning units, etc.) can create negative pressure. If the boiler is operated at the same time, this can lead to a reverse flow of flue gas.

Index

Service instructions

Information

| | |
|----------------------------|---|
| Disposal of packaging..... | 7 |
| Symbols..... | 8 |
| Intended use..... | 9 |
| Product information..... | 9 |

Installation instructions

Preparing for installation

| | |
|-------------------------------|----|
| Installation information..... | 10 |
|-------------------------------|----|

Installation sequence

| | |
|-------------------------------------|----|
| Opening the controller..... | 11 |
| Fitting the wall mounting base..... | 11 |
| Electrical connections..... | 12 |
| Assembling the controller..... | 14 |

Service instructions

Commissioning and adjustment

| | |
|--|----|
| Starting up the room temperature controller..... | 15 |
| Setting the mixer extension kit parameters..... | 15 |
| Further settings..... | 16 |

Troubleshooting









| | |
|---|----|
| Fault messages..... | 23 |
| Scanning temperatures and programs..... | 23 |

| | |
|--------------------|----|
| Specification..... | 25 |
|--------------------|----|

Disposal of packaging

Please dispose of packaging waste in line with statutory regulations.

Symbols

| Symbol | Meaning |
|---|--|
|  | Reference to other document containing further information |
|  | Step in a diagram: The numbers correspond to the order in which the steps are carried out. |
|  | Warning of material losses and environmental pollution |
|  | Live electrical area |
|  | Pay particular attention. |
|  | <ul style="list-style-type: none"> ■ Component must audibly click into place. or ■ Acoustic signal |
|  | <ul style="list-style-type: none"> ■ Fit new component. or ■ In conjunction with a tool: Clean the surface. |
|  | Dispose of component correctly. |
|  | Dispose of component at a suitable collection point. Do not dispose of component in domestic waste. |

Intended use

The appliance is intended solely for installation and operation in sealed unvented heating systems that comply with EN 12828, with due attention paid to the associated installation, service and operating instructions. It is only designed for heating up heating water that is of potable water quality.

Intended use presupposes that a fixed installation in conjunction with permissible, system-specific components has been carried out.

Commercial or industrial usage for a purpose other than heating the building or DHW shall be deemed inappropriate.

Any usage beyond this must be approved by the manufacturer in each individual case.

Incorrect usage or operation of the appliance (e.g. the appliance being opened by the system user) is prohibited and will result in an exclusion of liability. Incorrect usage also occurs if the components in the heating system are modified from their intended use (e.g. if the flue gas and ventilation air paths are sealed).

Product information

Room temperature controller

- For room temperature-dependent mode or weather-compensated mode of the heat generator.

Weather-compensated mode in conjunction with an outside temperature sensor (separate accessories).

- For controlling a heating circuit without a mixer and/or a heating circuit with a mixer in conjunction with the OpenTherm mixer extension kit (separate accessories).

Room temperature-dependent mode or weather-compensated mode in conjunction with an outside temperature sensor (separate accessories).

Installation information

Installation location for room temperature-dependent mode

- On an internal wall in the main living room, approx. 1.5 m above the floor
- Not next to windows or doors
- Not above radiators
- Not between shelves, in recesses, etc.
- Not near heat sources (direct insolation, fireplace, TV set, etc.)

Note on operation as a room temperature controller

Do not install further control devices in the main living room. If the radiators are equipped with thermostatic valves, these must always be fully open.

Installation location for weather-compensated mode

The device can be installed anywhere in the room.

Opening the controller

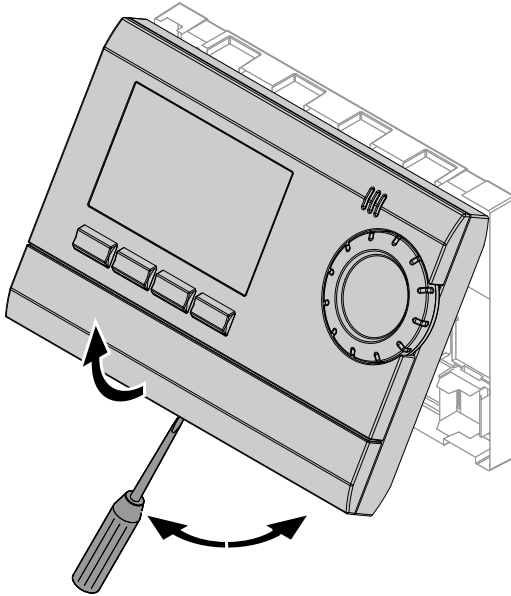

Fitting the wall mounting base

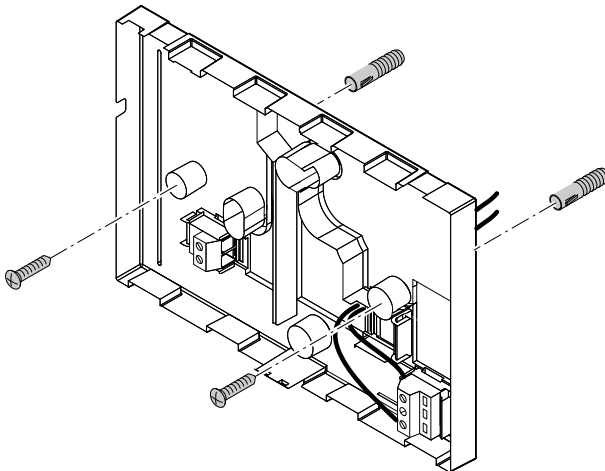

Electrical connections

Connection to the heat generator control unit

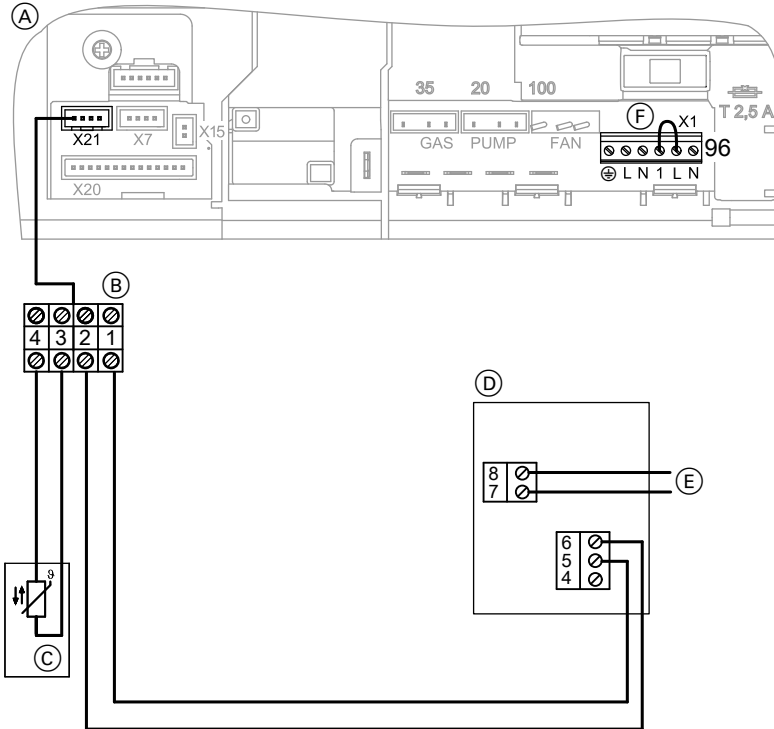

- (A) Boiler control unit
- (B) Terminals on the control unit
- (C) Outside temperature sensor
- (D) Room temperature controller
- (E) Input for on-site switching contact
- (F) Remove jumper when connecting.

Recommended connecting cable
■ 2-core cable for extra low voltage



Please note
Incorrect connection will damage the room temperature controller.
Do **not** connect the room temperature controller to plug 96.

Connecting the on-site switching contact

Connection at terminals 7 and 8

Electrical connections (cont.)

On-site switching contact: Floating contact, electrically isolated

The following functions can be connected:

- Window contact (operation with frost protection temperature when contact is open)
- Telephone contact (telephone remote switch)
- Presence detector (switching contact)

Connection to mixer extension kit

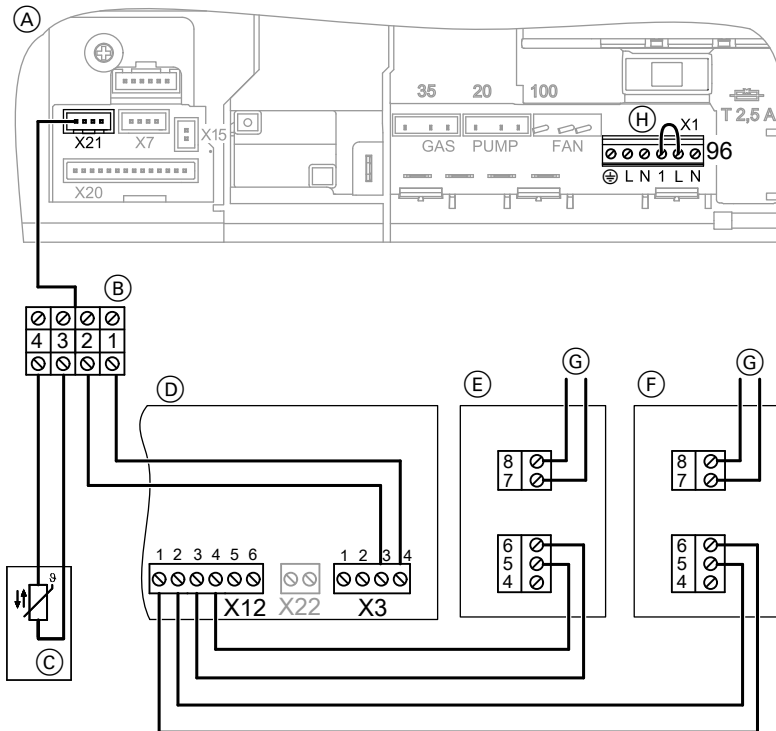

- (A) Boiler control unit
- (B) Terminals on the control unit
- (C) Outside temperature sensor
- (D) Mixer extension kit

- (E) Room temperature controller for heating circuit without mixer
- (F) Room temperature controller for heating circuit with mixer
- (G) Input for on-site switching contact

Electrical connections (cont.)

Ⓜ Jumper

1. Connect the heat generator control unit and the room temperature controller.
2. Remove jumper Ⓜ.

Connecting the on-site switching contact

Connection at terminals 7 and 8

On-site switching contact: Floating contact, electrically isolated

The following functions can be connected:

- Window contact (operation with frost protection temperature when contact is open)
- Telephone contact (telephone remote switch)
- Presence detector (switching contact)

Assembling the controller

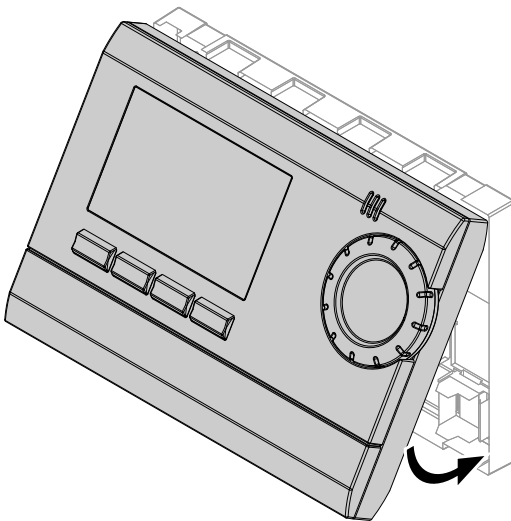

Starting up the room temperature controller

Information on language setting

If a particular language is not available, set the operating language to English.

Available languages:

- German
- Danish
- English
- French
- Italian
- Dutch
- Polish
- Spanish
- Czech
- Turkish
- Hungarian

1. Turn on the ON/OFF switch on the boiler control unit.

The following information appears in sequence:

- Segment test (all symbols are displayed)
- Equipment code and software version (10.64 or 10.65)
- **"OPEN THERM"**
If **"0 - 10 V"** appears here, select **"OPEN THERM"**. See page 18.
- If **"OT CONTROL"** flashes, enter the following settings:

2. Change settings with +/- or the rotary selector, and confirm with **OK**.
 - Select the operating mode:
 - For room temperature-dependent mode: **"ROOM-CONTROL"**
 - For weather-compensated mode: **"OT CONTROL"**
An outside temperature sensor must be connected to the boiler control unit.
 - **"LANGUAGE"**
 - **"YEAR"**
 - **"MONTH"**
 - **"DAY"**
 - **"HOUR"**
 - **"MINUTE"**

Commissioning is complete when the current room temperature appears.

For further settings, see page 16.

Note

*The automatic summer/wintertime changeover can be set under **"SU/WI RULE"**.*



Operating instructions

Setting the mixer extension kit parameters

Calling up and changing parameters

Display and adjustment are made on the room temperature controller.

1. Press **MODE**.

2. Use <-/-> to select **"SETTINGS"**.
3. **OK** to confirm

Setting the mixer extension kit parameters (cont.)

4. Use <-/-> to select **"SERVICE"**.
5. **OK** to confirm
6. Use <-/-> to select **"TSP-PARAMETER"**.
7. **OK** to confirm
8. Use <-/-> to select the required parameter.
9. **OK** to confirm
10. Set the required value with +/-.
11. **OK** to confirm



For information on the parameters, see the installation and service instructions for the heating circuit extension kit.

Further settings

1. Press **MODE**.
2. Use <-/-> to select **"SETTINGS"**.
3. **OK** to confirm
4. Use <-/-> to select **"SERVICE"**.
5. **OK** to confirm
6. Use <-/-> to select the required setting.
See following chapter.
7. **OK** to confirm

Temperature balancing (wall compensation)

If the controller is mounted in an unfavourable installation location, the room temperature displayed may deviate from the actual room temperature. The temperature deviation can be adjusted with a correction value.

1. Use <-/-> to select **"WALL COMP"**.
2. **OK** to confirm
3. Use +/- or the rotary selector to set the required corrected temperature.
4. **OK** to confirm

Further settings (cont.)

Start optimisation

Only for room temperature-dependent mode: The controller uses the difference between the set and actual room temperatures to determine how far in advance to set the central heating start time. This ensures that the set room temperature is achieved at the beginning of the set time phase.

Example: With a temperature differential of 6 K and a setting of 5 min/K, central heating starts 30 min earlier.

Factory setting 00 (no start optimisation)

1. Use <-/-> to select "**OPTIMISE**".
2. **OK** to confirm
3. Use +/- or the rotary selector to set the required optimisation value in min/K.
4. **OK** to confirm

External input

1. Use <-/-> to select "**EXT INPUT**".
2. **OK** to confirm
3. Use +/- or the rotary selector to set the required function. See the table below.

Set "EXT INPUT" according to the connected function:

| Function | Setting |
|---|---|
| No function connected | " UNUSED INPUT " |
| Window contact (operation with frost protection temperature when contact is open) | " WINDOW SWITCH " |
| Telephone contact (telephone remote switch) | " PHONE SWITCH " Further settings: <ul style="list-style-type: none"> ■ Required set room temperature ■ Required runtime The function can be terminated with " OFF " before the set time has elapsed. |
| Presence detector (switching contact) | " PRESENCE DETECTOR " Further settings: <ul style="list-style-type: none"> ■ Required set room temperature |
| Sensor functions | Do not adjust |



Further settings (cont.)

4. **OK** to confirm

5. If possible, enter further settings and confirm with **OK**.

Device type

The factory setting for "**DEVICE TYPE**" is "**OPEN THERM**". If this is not the case, set "**OPEN THERM**".

1. Use <-/-> to select "**DEVICE TYPE**".

2. **OK** to confirm

3. Use +/- or the rotary selector to select "**OPEN THERM**".

4. **OK** to confirm

Control characteristics

Various parameters for control characteristics can be changed, depending on the selected operating mode. See following chapter.

1. Use <-/-> to select "**CONTROL**".

2. **OK** to confirm

3. Use <-/-> to select the following, depending on the operating mode:

- "**ROOM-CONTROL**" for room temperature-dependent mode
- "**OT CONTROL**" for weather-compensated mode

4. **OK** to confirm. The first adjustable parameter is displayed.

5. Use +/- or the rotary selector to set the required value.

6. **OK** to confirm. The display switches to the next parameter.

Settings for weather-compensated mode ("**OT CONTROL**")

Heating curve

The heating curve can be changed with the following parameters:

- Low end (heating flow temperature at outside temperature + 20 °C)
- End point (heating flow temperature at outside temperature - 15 °C)
- Shift (setback in reduced mode)

Further settings (cont.)

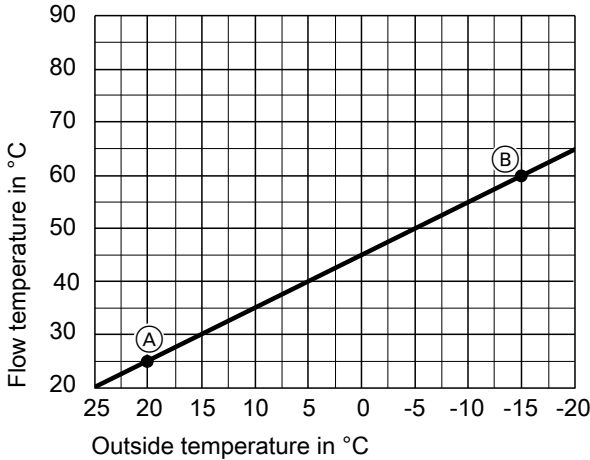

| Parameter | Setting range | Delivered condition |
|---------------|---------------|---------------------|
| Low end (A) | 10 - 40 °C | 25 °C |
| End point (B) | 25 - 90 °C | 60 °C |
| Shift | 5 - 35 K | 25 K |

The heating curve is limited at the upper end by the maximum flow temperature ("MAX TEMP").

Note

If the room temperature controller acts on 2 heating circuits (heating circuit with mixer and heating circuit without mixer), 2 heating curves can be set.

- Heating curve 1 acts on the heating circuit without mixer.
- Heating curve 2 acts on the heating circuit with mixer.
- The set switching times act on both heating circuits.

Maximum flow temperature limit

To limit the heating curve at the upper end.

"MAX TEMP" adjustable from 0 - 90 °C
Factory setting 90 °C

Room influence factor

If the actual room temperature deviates too much from the set room temperature, the set flow temperature can be raised by a factor per 1 K deviation. The higher the value for "ROOM INFLUENCE", the greater the increase in the set flow temperature.

"ROOM INFLUENCE" adjustable from 0 - 10
Delivered condition 0

Further settings (cont.)

Heating limit

Heating mode ends when the set outside temperature ("**HEATING OFF AT**") is reached.

"HEATING OFF AT" adjustable from 15 - 25 °C

Delivered condition - -

Settings for room temperature-dependent mode ("**ROOM-CONTROL**")

Depending on the set and actual room temperatures, the required flow temperature is determined and transmitted to the heat generator control unit.

Maximum flow temperature limit

To limit the set flow temperature at the upper end.

"MAX TEMP" adjustable from 0 - 90 °C
Factory setting 90 °C

Selecting the set flow temperature change via P value

With the "**P-BAND**" setting, the change characteristics of the flow temperature are influenced subject to the actual room temperature and the set max. flow temperature.

"P-BAND" adjustable from 1.0 - 2.0 K
Factory setting 1.6 K

Example:

- Max. flow temperature 80 °C (factory setting)
- Set room temperature 20 °C
- Stop hysteresis 0.4 K (fixed)

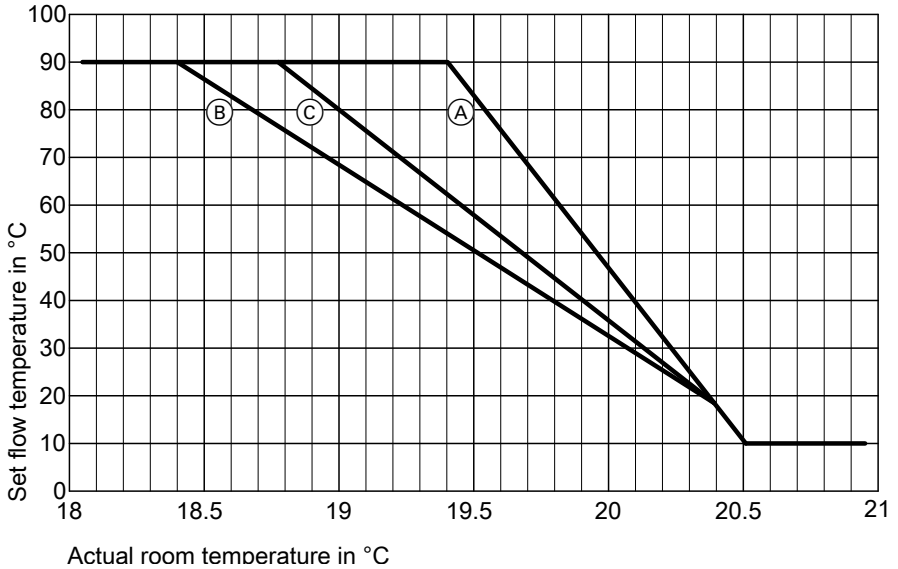
Further settings (cont.)

- (A) P 1.0 K
- (B) P 2.0 K
- (C) P 1.6 K (factory setting)

Setting the I component time

With the "I-TERM" setting, the change characteristics of the flow temperature are recorded during a set period.

"I-TERM" adjustable from 2 - 15 min
Factory setting 10 min

- If the actual room temperature is < the set room temperature and the actual room temperature has not increased during the I-time, the set flow temperature is increased by 1 K.
- If the actual room temperature is > the set room temperature and the actual room temperature has not decreased during the I-time, the set flow temperature is reduced by 1 K.

Setting the service interval

"MONTHS BEFORE NEXT SERVICE"
adjustable from 1 - 60

Factory setting 00

Further settings (cont.)

Soft start

The "**SOFT START**" function is not active.

Emissions test function

The "**CHIMNEY SWEEP**" function is not active.

Fault messages

If a fault occurs, the display shows **"ERROR"**.

Press **INFO** to show the fault message.

| Fault message | Meaning |
|------------------------------------|--|
| "ERROR OUTSIDE TEMPERATURE" | Short circuit/lead break, outside temperature sensor |
| "ERROR - FLAME" | No flame signal |
| "ERROR - WATER TEMP" | Temperature limiter has responded |

Note

Fault messages which are displayed as a fault code can be found in the installation and service instructions for the heat generator.

*For messages **"ERROR D0"** to **"ERROR D5"**, see the installation and service instructions for the mixer extension kit.*

Scanning temperatures and programs

Press **INFO** to select the required scan.

Depending on the system configuration, not all scans are displayed.

| Scan | Meaning |
|-------------------------------|--|
| "ROOM TEMP" | Current room temperature |
| "OUTSIDE TEMP" | Current outside temperature |
| "P... ACTIVE" | Active program |
| "TARGET TEMP" | Set room temperature (for room temperature-dependent mode) |
| "FEED SETPOINT TEMP" | Set flow temperature for heating circuit (if 1 heating circuit is connected) or heating circuit without mixer (if 2 heating circuits are connected) |
| "FEED SETPOINT TEMP 2" | Set flow temperature for heating circuit with mixer (if 2 heating circuits are connected) |
| "ACTUAL FEED TEMP" | Actual flow temperature for heating circuit (if 1 heating circuit is connected) or heating circuit without mixer (if 2 heating circuits are connected) |
| "ACTUAL FEED TEMP 2" | Actual flow temperature for heating circuit with mixer (if 2 heating circuits are connected) |
| "HW SETPOINT TEMP" | Set DHW temperature |
| "ACTUAL HW TEMP" | Actual DHW temperature |

Scanning temperatures and programs (cont.)

| Scan | Meaning |
|---------------------------|--|
| "BURNER STARTS/10" | Displayed value multiplied by 10 gives the number of burner starts performed (not shown if connected to mixer extension kit) |
| "BURNER HOURS/10" | Displayed value multiplied by 10 gives the number of burner hours run (not shown if connected to mixer extension kit) |

Specification

| | |
|------------------|--|
| Power supply | Via OpenTherm |
| IP rating | IP 20 to EN 60529 |
| Protection class | II to EN 60730-1 subject to correct installation |
| Power reserve | 4 h |
| Accuracy | ≤ 1 s/day at 20 °C |







Viessmann Werke GmbH & Co. KG
D-35107 Allendorf
Telephone: +49 6452 70-0
Fax: +49 6452 70-2780
www.viessmann.com



Viessmann Limited
Hortonwood 30, Telford
Shropshire, TF1 7YP, GB
Telephone: +44 1952 675000
Fax: +44 1952 675040
E-mail: info-uk@viessmann.com

5837759 Subject to technical modifications.