

# ACO403

# Operating Manual

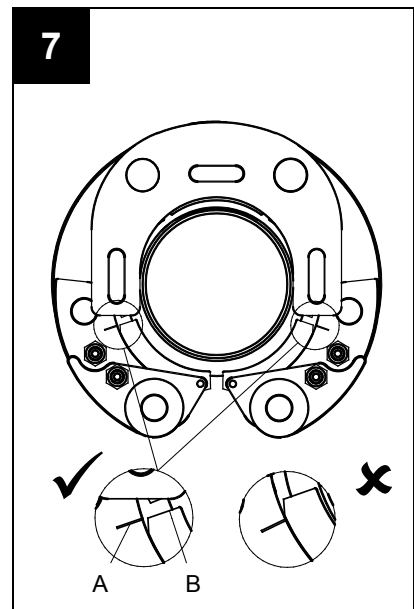

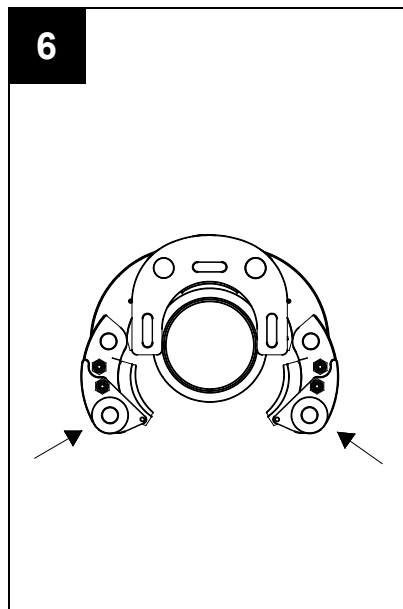
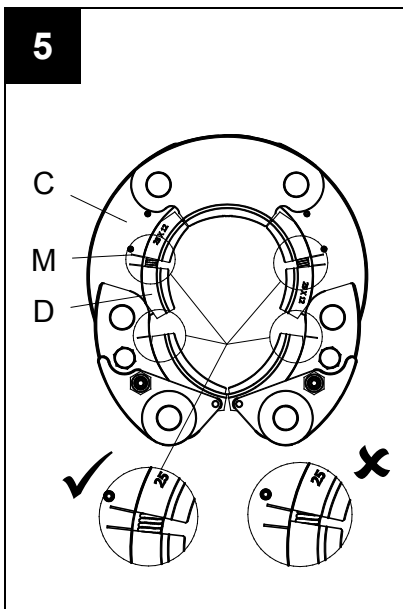
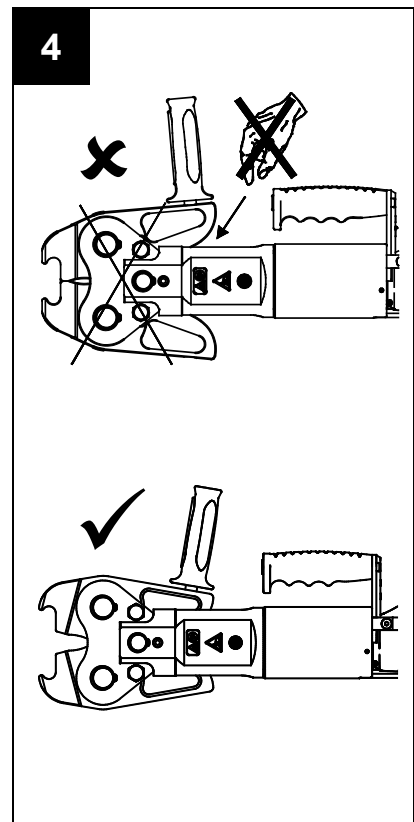
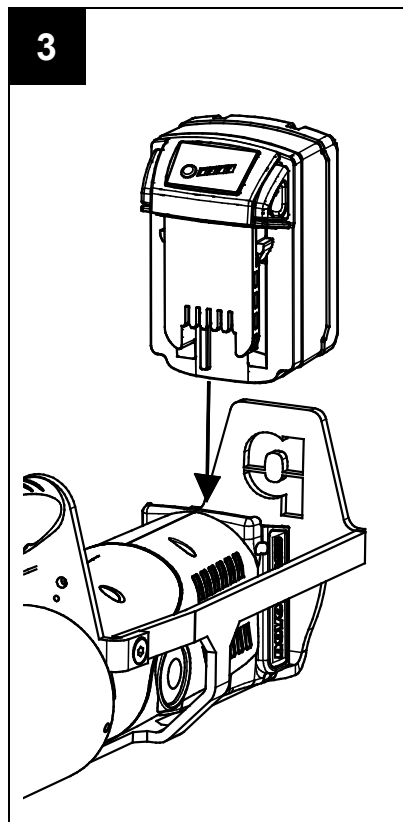
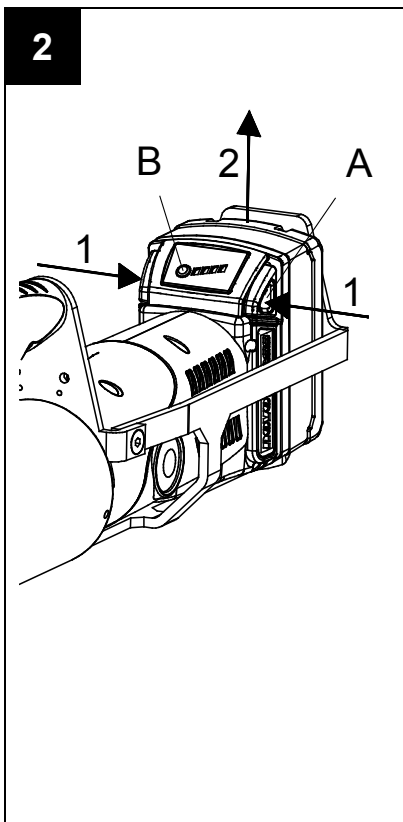
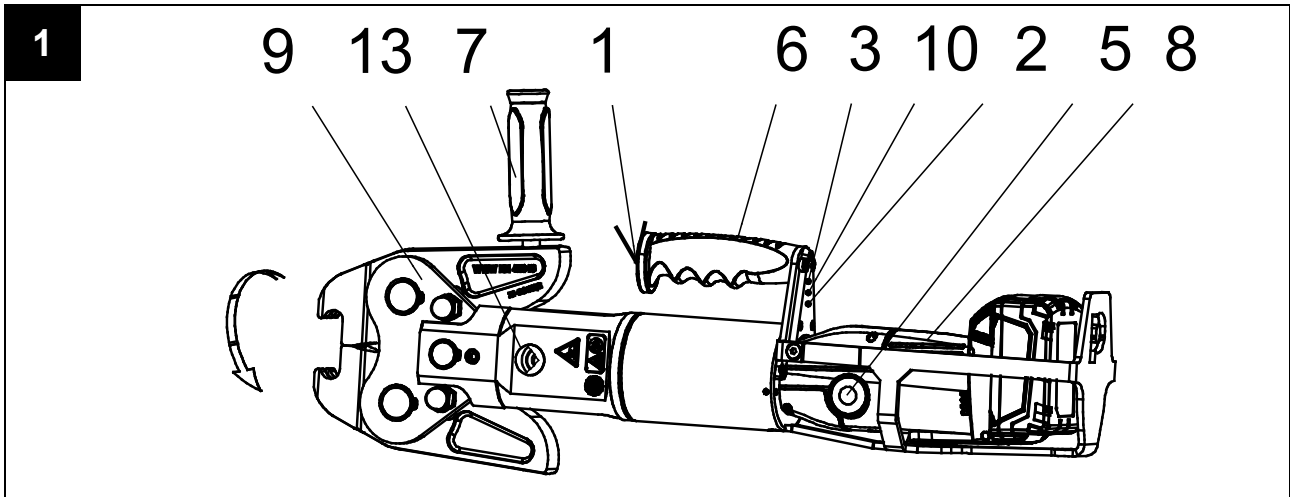
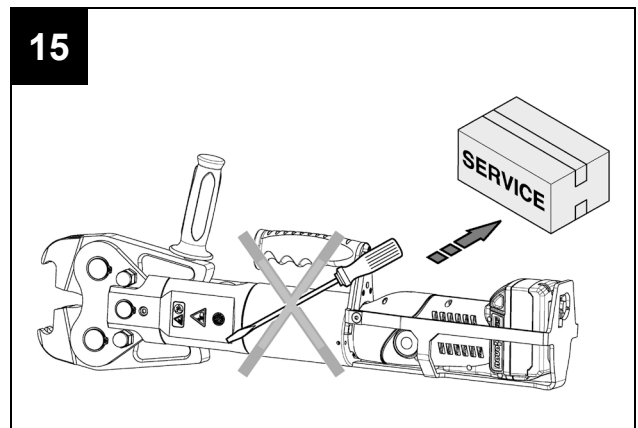
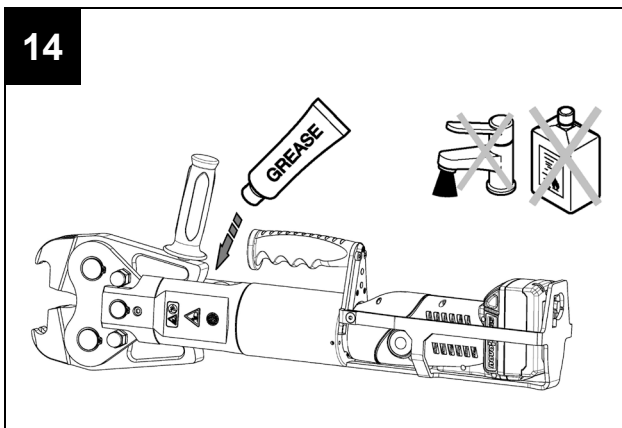
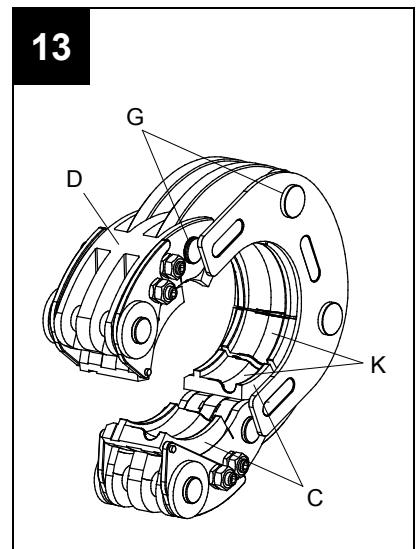
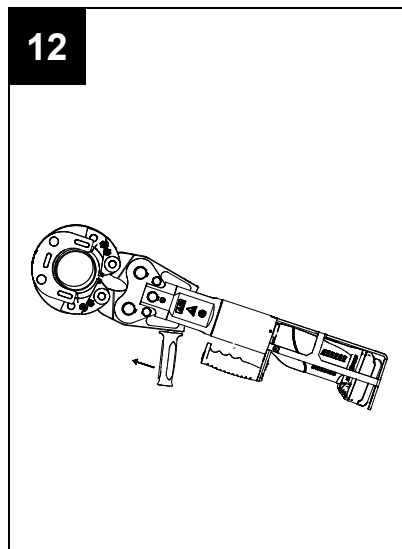
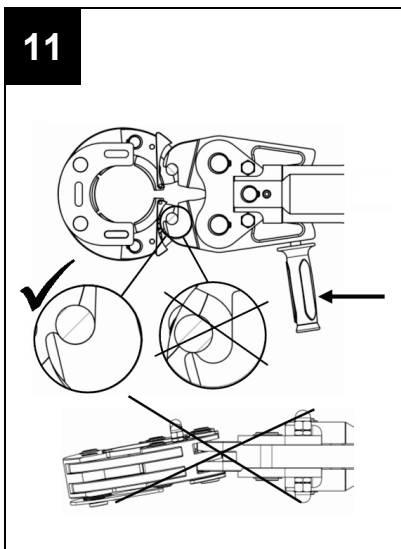
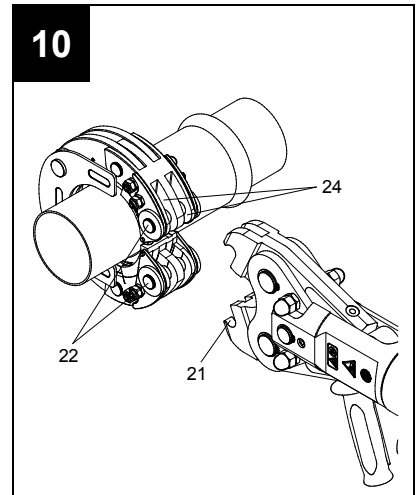
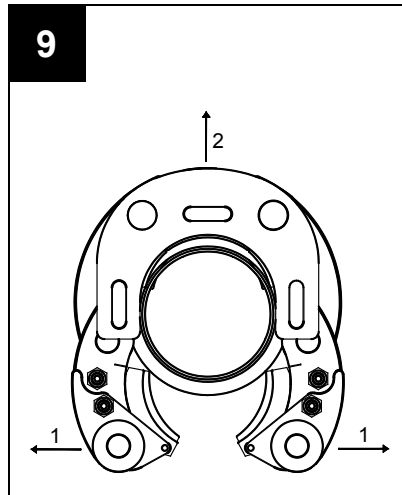
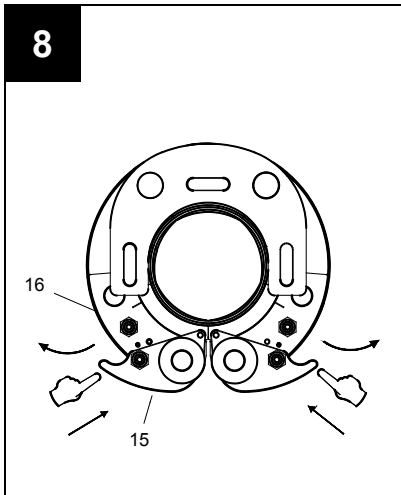

**ACO403**  
**EN English**  
**Translation of the original Operating Manual**

**Contents**

1	Proper use .....	4
2	Basic safety information .....	4
3	Definition of terms.....	6
4	Symbols on the device and information on the rating plate .....	6
5	Scope of supply .....	7
6	Technical Data.....	7
7	Brief description of the press device (Fig.1).....	8
8	Start-up and operation.....	9
9	Performing the pressing operation .....	11
10	Re-pressing .....	14
11	Cleaning, maintenance and repair .....	14
12	Disposal.....	15
13	Warranty and guarantee.....	15
14	EC Declaration of Conformity.....	16

**1 Proper use**

These press devices are intended exclusively for use with press collars manufactured by Novopress or approved by Novopress, in agreement with the system supplier. If you are uncertain whether your press device is suitable for the press tools described here, please contact the system supplier.

The devices and the press collars are to be employed solely for the purpose of press-fitting pipes and fittings for which the relevant press collars have been designed.

Any use beyond or different to that described here shall be regarded as improper use.

All work with this tool that does not correspond to proper use may lead to damage to the press device, the accessories or the pipes. Leaks and/or injury may result.

Novopress is not liable for damage resulting from

- the use of unsuitable press tools or press tools from other manufacturers, or
- applications that do not conform to proper use.

Proper use also includes compliance with the Operating Manual, adherence to the inspection and maintenance conditions as well as compliance with the latest versions of all relevant safety regulations.

**2 Basic safety information**

The following pictograms are used to highlight sections of text. Please follow these instructions and act with particular caution in these cases. Pass all health and safety instructions on to other users and technicians.

	<p><b>WARNING!</b></p> <p>This information indicates a potentially dangerous situation that could result in serious injury or death.</p>
---	--

	<p><b>CAUTION!</b></p> <p>This information indicates a potentially dangerous situation that could result in minor injuries and/or material damage.</p>
---	--

**Information!**

This information is directly linked to the description of a function or an operating sequence.

**Please read this Operating Manual carefully.**

**The safety instructions it contains must be observed.**

**Compliance with local safety regulations is essential!**

**WARNING!**
**Read all safety warnings and all instructions.**

Failure to follow the warnings and instructions may result in electric shock, fire and/or serious injury.

Therefore:

- Save all warnings and instructions for future reference.

**WARNING!**
**Risk of injury from ejected fragments**

Incorrect or improper use or the use of worn or damaged press tools and press devices carries a risk of injury from ejected fragments.

Therefore:

- Press tools and press devices may only be used by trained personnel.
- Compliance with the specified service work and service intervals is mandatory.
- Check the press tools and press devices for cracks and other signs of wear before each use.
- Separate all press tools and press devices with material cracks or other signs of wear immediately and do not use them any longer.
- Only use press tools and press devices that are in perfect technical condition.
- Following incorrect use, do not use the press tool and press device any longer and have them inspected by an authorised workshop.

**CAUTION!**
**Unskilled use may lead to a damaged or malfunctioning press tool and press device.**

Therefore:

- Replace worn press tools immediately and do not use them any longer.
- Use carrying cases for transport and storage and keep press tools and the press device in a dry room.
- Have damage checked immediately by an authorised workshop.
- Comply with the safety instructions regarding the cleaning and anti-corrosion agents used.

**Information!**

Consult the documents provided by the system supplier for handling and assembly instructions for fittings and pipes.



### 3 Definition of terms

V	volt
A	ampere
Hz	hertz
W	watt
kW	kilowatt
g	gram
kg	kilogram
Bj	year of manufacture

Ah	ampere hour
db(A)	decibel (sound pressure)
bar	bar
°C	degree Celsius
kN	kilonewton
a.c.	Alternating current voltage
d.c.	Direct current voltage
F	force

Ø	diameter
h	hour
min	minute
s	second
m/s <sup>2</sup>	metre divided by square second (acceleration)
Nr	number

### 4 Symbols on the device and information on the rating plate

Symbol	Meaning
	Warning: Danger of crushing
	Service sticker; indicates when the next service is due.
	Warning – ejected fragments

#### Information on the rating plate

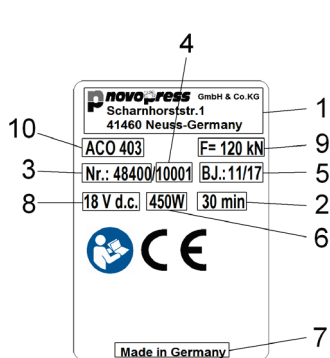



1	Manufacturer logo incl. address
2	Permissible uninterrupted operating time
3	Part No.
4	Serial No.
5	Year of manufacture mm.yy

6	Power consumption
7	Country of manufacture
8	Permissible voltage range in volt
9	Nominal force
10	Type designation of device

#### Explanation of possible pictograms on the rating plate

	Verification marking Canada/ USA
	Verification marking Canada/ USA
	Registration of products on the uniform customs territory

	Verification marking Australia
	CE conformity marking product safety in Europe
	Read Operating Manual

## 5 Scope of supply

The scope of supply for the standard equipment includes:

ACO403
press device incl. Operating Manual
Press collar in separate carrying case
Battery charger incl. operating manual
18 V d.c. rechargeable battery
Safety instructions
EC Declaration of Conformity
Carrying case

Other accessories may be included as additional extras. Please contact the system supplier for information on the supply scope.

## 6 Technical Data

<b>Device:</b>	<b>ACO403</b>
Rated voltage:	18 V d.c.
Nominal force:	120 kN
Height:	320 mm
Length:	650 mm
Width:	102 mm
Net weight:	12,8 kg (without battery)
Max. noise level:	91 db(A) <sup>1)</sup>
Noise pressure level at user's ear:	80 db(A) <sup>1)</sup>
Vibration value:	<2,5 m/s <sup>2</sup> <sup>2)</sup>
Type of protection:	IP20
Temperature range during operation:	-10°C to +50°C

1) Measurement uncertainty 3 db(A)

2) Measurement uncertainty 1,5 m/s<sup>2</sup>



### Information!

Wear hearing protection.

The stated vibration emission value was measured using a standard test procedure and can be employed for the purpose of comparison with another device.

The stated vibration emission value can also be used to obtain an initial estimate of interruptions during intermittent operation.

**Caution** The vibration emission value may differ from the stated value while the device is actually in use, depending upon the manner in which the device is used. It may be necessary to establish safety measures to protect operating personnel, depending on the actual conditions of use (intermittent operation).

### Battery charger

For information on the function and operation of the battery charger and the rechargeable batteries, please consult the battery charger operating instructions.

## **7 Brief description of the press device (Fig.1)**

The ACO403 press device comprises the press device (8) and a fixed adaptor jaw (9). The head with the adaptor jaw can be rotated through 180°. It is only possible to adjust the head before the pressing operation. The head cannot be rotated while the pressing operation is being performed.

To carry out the pressing operation, hold the device tightly on handle (6) and on grip (7) on the adaptor jaw.

### **7.1 Automatic press cycle (Fig. 1)**

The device features an automatic press cycle. This ensures that the pressing operation is completed every time. For safety reasons, the automatic press cycle only switches on when the pressing operation has started, i.e. from when the fitting starts to be shaped.

After the automatic press cycle has been triggered, the green LED (2) goes out and the pressing operation runs automatically. The pressing operation can then only be stopped by pressing and holding release button (5). After the pressing operation has been completed, the motor automatically switches off and the green LED (2) lights up again.

If start button (1) is released before the automatic press cycle begins, the piston in the press device moves back to its starting position. The pressing operation will not have been completed. The pressing operation must be triggered again.

### **7.2 Release button**

In the event of an emergency, the pressing operation can be stopped at any time by pressing and holding release button (5). The piston in the press device then returns to its starting position.

### **7.3 Wireless interface (Fig. 1)**

The ACO403 device features a wireless interface with the following characteristics:

- Blue LED (10)
- Wireless icon (13)



This wireless interface together with the NovoCheck app can be used to connect the ACO203 to a mobile terminal, such as a smartphone, tablet, etc. (Android, IOS; further information at [www.novopress.de](http://www.novopress.de)). The following functions are available:

- Readout of the press device
- Checking the press device
- Making settings
- Generating construction site reports.

To establish a connection, the press device must be operational and the NovoCheck app installed on the terminal device.

The press device can now be connected with the NovoCheck app. (For more information, go to [www.novopress.de](http://www.novopress.de)) When the connection was established successfully, the blue LED lights up.

The blue LED goes out if no connection has been established until the first pressing operation is performed. A new attempt to establish the connection can only be made if the press device has been switched off in the meantime. It may be necessary to pull the rechargeable battery for this.

If you do not wish to establish a connection, press the start button once again and perform the pressing operation.

### **7.4 Battery**

#### **Removing the battery (Fig. 2)**

Push in (1) the two release buttons (A) and then remove the battery (2).

#### **Inserting the battery (Fig. 3)**

Slide the battery into the device as illustrated until it clicks into place.



**Battery level indicator (Fig. 2)**

The battery level is displayed when button (B) is pressed. The number of LEDs lit up denotes the battery level.

If the battery is inserted in the press device when the battery level is checked, the last pressing operation must have been completed at least 1 minute prior to this. Otherwise the display will be inaccurate.

	<p><b>Information!</b></p> <p>The ACO403 press device must only be operated with 3.0 Ah 18 V rechargeable lithium-ion batteries. The rechargeable 18 V battery must only be used in the appropriate press devices.</p>
---	--

**Feature of the press device when the battery is empty:**

When a pressing operation begins, a check is made to determine whether the battery charge is sufficient to complete the pressing operation. If this is not the case the device does not start. The green LED (2) flashes.

If the green LED (2) flashes following a pressing operation, the pressing operation was carried out correctly. The battery must be recharged prior to the next pressing operation.

**7.5 Energy saving mode**

If the press device is not used over an extended period, the device switches off. No LED is lit up any longer. Press the start button (1) briefly to activate the press device.

**8 Start-up and operation**

	<p><b>CAUTION!</b></p> <p><b>Fingers risk being crushed if the device is operated without a press collar. (Fig. 4a)</b></p> <p>If the press device is not placed on a press collar, fingers could be placed in the at-risk zone. Fingers could be crushed when the device is started.</p> <p>Therefore</p> <ul style="list-style-type: none"> <li>- Do not operate the device without a press collar.</li> <li>- Keep your fingers away from the at-risk zone</li> </ul>
---	--

	<p><b>Information!</b></p> <p>The ACO 401 press device is not suitable for continuous operation. A short break of at least 15 minutes must be taken after approx. 15-20 pressing operations in succession in order to allow the device to cool down.</p>
---	--

## 8.1 Meaning of the LED display

LED display	Status/cause	Measure
Green LED (2) lights up.	On standby.	
Green LED (2) off (pressing operation in progress).	Automatic press cycle is on, device ends the pressing operation automatically.	
Green LED (2) flashes.	Insufficient battery charge.	Charge or replace battery.
Blue LED (10) flashes.	The press device is ready for connection.	The press device can be connected with the NovoCheck app.
Blue LED (10) lights up.	The press device is connected with the NovoCheck app.	
Red LED (3) flashes.	Device not within the temperature range	The device only works within a temperature range of -10 to +50°C. If the red LED is flashing, the device must be moved into a warmer or colder area. The device can be warmed to operating temperature by means of dry runs. If the device is too warm it must be cooled down by means of a short break.
Red LED (3) lights up.	Device fault.	Press the start button (1). If this is unsuccessful, the press device is defective. Send the device to a specialist workshop. <b>NOTE!</b> The pressing operation may not have been completed; please check and repeat if required.
Red (3) and green (2) LED flash alternately.	Service interval reached.	Take the press device to be serviced within the next 100 pressing operations.

## 8.2 Starting position of the press collar (Fig. 5)

	<p><b>Information!</b></p> <p>To ensure that the press collars function correctly, the sliding segments must be free to move.</p> <p>The sliding segments are always pressed back automatically into the correct starting position by springs.</p> <p>Therefore:</p> <ul style="list-style-type: none"> <li>– Ensure that marking lines (M) on shells (C) are aligned with the edges of the sliding segments (D) when the press collar is in starting position. (Fig. 5)</li> <li>– If this is not the case, have the press collars repaired.</li> </ul>
---	--

The press collar must be positioned in the way shown (oval shape) before it is placed on a fitting. After the press collar has been opened and removed from a fitting, the press collar must again be positioned in the way shown.

### 8.3 Closing the collar (Fig. 6 + 7)

- By pressing the outer end of the shell gently, the shell moves inwards. (Fig. 6)

	<p><b>CAUTION!</b></p> <p><b>There is a risk that the press collar will break if it is positioned incorrectly</b></p> <p>If the press collar is positioned incorrectly on the fitting the press collar may become damaged.</p> <p>Therefore:</p> <ul style="list-style-type: none"> <li>– The line (A) must be at the same height of the edge (B). (Fig. 7)</li> <li>– If this is not the case, remove the press collar again and reposition it.</li> </ul>
---	---

- The line (A) must be at the same height of the edge (B) when the press collar is positioned correctly. (Fig. 7)

### 8.4 Opening the collar (Fig. 8 + 9)

To open the press collar, the two outer shells can be swivelled away from the pipe, either individually or together, as described below.

First try the process with one hand before you try it with both hands together.

If you just open one side first and then the other you must hold the press collar tightly when opening the second side so that it does not fall off.

- To open the press collar the following 2 steps must be carried out. (Fig. 8)
  - Press lever (15) at the position marked in the direction of the pipe and hold it there.
  - Grip shell (16) at the position marked from below and swivel it away from the pipe.
- Once a certain point has been reached the shell automatically moves to its final position and makes an audible click.
- By pulling the two outer shells (16) apart, open the press collar far enough to remove it from the press fitting. (Fig. 9)

## 9 Performing the pressing operation

	<p><b>WARNING!</b></p> <p><b>Risk of injury from ejected fragments</b></p> <p>Incorrect or improper use of press tools or the use of worn or damaged press tools carries a risk of injury from ejected fragments.</p> <p>Therefore</p> <ul style="list-style-type: none"> <li>– Ensure that the nominal size of the press fitting matches the nominal size of the press tool.</li> <li>– Make sure that there is no dirt, swarf etc. between the press tool and the press fitting.</li> <li>– Do not hold the press tool askew on the press fitting.</li> <li>– If a press tool is used incorrectly, do not use it any longer and have it inspected by an authorised workshop.</li> </ul>
---	---

	<p><b>WARNING!</b></p> <p><b>Risk of injury from ejected fragments</b></p> <p>Material fatigue may cause the press tool to break.</p> <p>Press tools are wearing parts.</p> <p>Frequent pressing will result in material fatigue. Press tools worn or damaged in any other way as the result of material fatigue can break even if used correctly; there is then a risk of injury from ejected fragments. The risk of breakage is further increased in the event of improper use.</p> <p>Therefore</p> <ul style="list-style-type: none"> <li>– Check the press tools for cracks and other signs of wear before each use.</li> <li>– Discard all press tools with material cracks or other signs of wear immediately and do not use them any longer.</li> <li>– Only use press tools that are in perfect technical condition.</li> </ul>
---	--

	<p><b>CAUTION!</b></p> <p><b>Danger of crushing!</b></p> <p>There is a risk of fingers and hands becoming crushed.</p> <p>Therefore</p> <ul style="list-style-type: none"> <li>– Keep all body parts and foreign objects away from the jaw levers on the fixed adaptor jaw when initiating the pressing operation.</li> <li>– Do not hold the jaw levers of the adaptor jaw with your hands during the pressing operation. Use the grip (7). (Fig. 1)</li> </ul>
---	--

	<p><b>CAUTION!</b></p> <p><b>Keep fingers away from the at-risk zone when the adaptor jaw is closed. (Fig. 4a)</b></p> <p>Fingers may get crushed.</p> <p>Therefore</p> <ul style="list-style-type: none"> <li>– Leave the adaptor jaw open. (Fig. 4b)</li> </ul>
--	---

	<p><b>Information!</b></p> <p>To ensure that the press collars function correctly, the sliding segments must be free to move.</p> <p>The sliding segments are always pressed back automatically into the correct starting position by springs.</p> <p>Therefore:</p> <ul style="list-style-type: none"> <li>– Ensure that marking lines (M) on shells (C) are aligned with the edges of the sliding segments (D) when the press collar is in starting position. (Fig. 5)</li> <li>– If this is not the case, have the press collars repaired.</li> </ul>
---	--

1. Check that the nominal size of the press fitting matches the nominal size of the press collar.

	<p><b>Information!</b></p> <p>Comply with the system supplier's instructions when positioning the press collar on the press fitting.</p>
---	--

	<p><b>CAUTION!</b></p> <p><b>There is a risk that the press collar will break if it is positioned incorrectly</b></p> <p>If the press collar is positioned incorrectly on the fitting the press collar may become damaged.</p> <p>Therefore:</p> <ul style="list-style-type: none"> <li>– The line (A) must be at the same height of the edge (B). (Fig. 7)</li> <li>– If this is not the case, remove the press collar again and reposition it</li> </ul>
---	--

2. Swivel the outer shells of the press collar outwards as far as possible and then position the press collar on the press fitting.
3. Close the press collar. (Fig. 6)
4. Open the adaptor jaw fully using the grip.

	<p><b>WARNING!</b></p> <p><b>Risk of injury from ejected fragments</b></p> <p>If the adaptor jaw is positioned on the press collar incorrectly, the adaptor jaw and the press collar may break.</p> <p>Therefore</p> <ul style="list-style-type: none"> <li>– Claws (21) of the adaptor jaw must grip pins (22) of the press collar. (Fig. 11, 12 + 13)</li> </ul>
---	--

5. Position the adaptor jaw on the press collar as follows.  
Push claws (21) of the adaptor jaw as far as possible into grooves (24) in the press collar. (Fig. 10)
6. Close the adaptor jaw using the grip.

	<p><b>Information!</b></p> <p><b>Ensure there is no gap between the segments of the press collar when the pressing operation is complete.</b></p>
---	---

	<p><b>Information!</b></p> <p><b>If the press device is switched off, briefly press the start button (1) to activate the press device. Press the start button again to start the pressing operation.</b></p>
--	--

7. In order to start the process, press the start button and hold it down.
8. After the pressing operation has been completed, open the adaptor jaw using the grip and detach it from the press collar.
9. Open the press collar and remove it.

## 10 Re-pressing

Re-pressing is always necessary if a pressing operation has not been fully completed. Check the system supplier's instructions to ascertain whether re-pressing is permitted. If it is permitted, please note the following differences from the initial pressing operation that must be complied with.

	<p><b>WARNING!</b></p> <p><b>Risk of injury from breaking claws on the adaptor jaw and damaged pins on the press collar</b></p> <p>Holding the press device incorrectly and changing its position before and during re-pressing means that the claws can no longer grip the pins properly. The tips of the claws may press directly on the pins, causing the claws and pins to break and fragments to fly off.</p> <p>Therefore:</p> <ul style="list-style-type: none"> <li>– After positioning on the press collar, press the jaw levers on the adaptor jaw together as far as possible using the grip. (Fig. 12)</li> <li>– Make sure that the claws of the adaptor jaw always grip the press collar pins throughout the re-pressing operation. (Fig. 11)</li> </ul>
---	--

## 11 Cleaning, maintenance and repair

	<p><b>CAUTION!</b></p> <p><b>Risk of injury during cleaning or repair work from inadvertently pressing the On switch.</b></p> <p>Therefore:</p> <ul style="list-style-type: none"> <li>– Comply with the safety instructions and always remove the battery before performing cleaning, servicing or repair work.</li> </ul>
--	---

### Service addresses

Novopress GmbH & Co. KG  
 Scharnhorststr. 1  
 41460 Neuss  
 Germany

You can find the addresses of authorised specialist workshops by contacting Novopress or at [www.novopress.de](http://www.novopress.de).

### Service intervals

Service and repair work may only be carried out by Novopress or the authorised Novopress specialist workshops.

	<p><b>Information!</b></p> <p>The next service is stated on the press device and the press collar.</p> <p>This service must be performed at least once a year. If more than 2500 pressing operations are carried out in a year, a service must be performed after these 2500 operations, at the latest.</p> <p>An LED indicates that the service interval is expiring 100 pressing operations in advance (see Section 8.1 Meaning of the LED display). )</p>
---	--

### Regularly (before use, at the start of the working day) and when soiled (Fig. 13)

- Check the press collar, adaptor jaw and device for visible defects such as damage, material cracks and other signs of wear. If defects are found, do not use the device any more. Replace it or send it to an authorised specialist workshop.
- Clean the press collar with compressed air.
- Lubricate the adaptor jaw pins.
- Spray the entire adaptor jaw with lubricant.
- Remove deposits from pressing contour (K).

- Clean press collar pressing contour (K).
- Completely coat pressing contour (K) with lubricant.
- Check that sliding segments (C) and shells (D) can move freely.

Recommended lubricant:

- enclosed oil
- oil containing MoS2

**After every 50 pressing operations:**

- Spray joints (G) of the press collars with lubricant.
- Spray lubricant between sliding segments (C) and shells (D).

**Six-monthly inspection**

Have the device inspected by a qualified electrician or a Novopress workshop

**Annually to get a 1-year extended warranty (see section 13 Warranty and guarantee)**

Have the press device inspected and serviced at Novopress or a Novopress workshop.

## 12 Disposal

	<p><b>CAUTION!</b>  <b>Groundwater hazard</b>  <b>The device contains hydraulic fluid.</b></p> <p>Hydraulic fluids pose a hazard to groundwater. Uncontrolled drainage or improper disposal is punishable by law.</p> <p>Therefore:</p> <ul style="list-style-type: none"> <li>– Dispose of the device in an environmentally responsible manner.</li> </ul>
---	---

The instructions in the operating instructions provided with the battery charger must be complied with when disposing of rechargeable batteries and the charger.

The product must not be disposed of as normal household waste.

Novopress recommends that disposal be carried out by authorised specialist companies.

Alternatively, waste devices can be returned directly to Novopress (or a specialist workshop) for proper disposal.

## 13 Warranty and guarantee

Novopress provides the full statutory warranty of 24 months for its press devices and tools. The warranty period always commences on the date of delivery, which must be proven by means of the sales documentation in case of doubt.

Within the warranty period, the warranty covers the repair of any damage or malfunction of these tools that is attributable to material or production faults.

The following are not covered by the warranty:

- Damage caused by improper use or inadequate servicing.
- Damage caused by the use of products not approved by Novopress for use with its press devices.
- Damage caused by pressing unsuitable pipes or fittings.

For wearing parts, the Novopress warranty lasts only for the intended service life.

Service work and parts provided in response to warranty claims do not have to be paid for. However, all shipping costs shall be borne by the user.

Claims can only be accepted if the device is delivered to Novopress or a Novopress workshop in an assembled state.

Repair or replacement of the device under warranty does not result in an extension of the warranty period. Repair or replacement can only be performed using as-new components, the function of which corresponds to that of the old components. All parts that are faulty and consequently replaced are the property of the manufacturer.

---

**Extended warranty on expiry of the statutory warranty period**

We voluntarily provide the following extended warranties beyond the statutory warranty period

**1-year extended warranty for new press devices, adaptor jaws and press collar**

Novopress provides an extended warranty of one year for all new press devices, adaptor jaws and press collars that have been serviced at least every 12 months by Novopress or by an authorised Novopress workshop. There is a charge for this service work. For details of costs, please contact Novopress or an authorised Novopress workshop.

**Repair warranty**

Novopress provides the following repair and spare parts warranty beyond the warranty period for new products that undergo repair after this period:

- 6-month warranty for replaced spare parts.
- 12-month warranty for replaced assemblies.
- 12-month warranty for replaced press devices.

## 14 EC Declaration of Conformity

EC declaration of conformity and list of maintained directives and applicable standards see attached document EC declaration of conformity.





**KE KELIT**®  
INNOVATIVE PIPE SYSTEMS

KE KELIT NZ Ltd.  
0800 4 KE KELIT  
0800 4 5353548  
info@kekelit.co.nz  
www.kekelit.co.nz

**novopress**

Scharnhorststr. 1  
41460 Neuss  
Germany

Postfach 101163  
41411 Neuss  
Germany  
Tel.: +49 (2131) 2880  
Fax: +49 (2131) 28855  
www.novopress.de  
E-mail: [info@novopress.de](mailto:info@novopress.de)